

LINE:	MEAT GRINDERS
--------------	----------------------

MODEL:	M-12-FS
---------------	----------------



USE	CAPACITY AND DIMENSIONS	
<ul style="list-style-type: none"> * Restaurants * Food service * Ranch * Hunting * Etc. 	MODEL	M-12 FS
	*Motor	3/4 HP / .55 kw
	**Grinding capacity (3/8)First Ground	3.3 kg/min/ 7.26 lb/min
	**Grinding capacity (1/8)Second Ground	1.8 kg/min/4.0 lb/min

*Motor available 110volts/60 Hz or 220 Volts/50 Hz optional
** 35° F / 2° C Fresh Meat, lab conditions

BENEFITS

- Specially designed for the food service market because of its compact size and reliability
- Compact size
- Stainless steel construction
- Powerful ¾ HP Motor
- Easy to clean

LINE: MEAT GRINDERS

MODEL: M-12-FS

BENEFITS



MINIMUM MAINTENANCE

Powerful oil bathed steel gears transmission, with no belts or pulleys to maintain



HYGIENIC

High grade stainless steel cabinet and tray, high corrosion resistant and easy to clean allowing a hygienic operation and a professional presentation

SPECIFICATIONS

MODEL	M-12-FS
*Motor	3/4 HP/ .55 kw
Volts	110/220 volts
**Grinding capacity (3/8)First Ground	3.3 kg/min/ 7.26 lb/min
**Grinding capacity (1/8)Second Ground	1.8 kg/min/4 lb/min
Net weight	36 kg/ 79 lb
Shipping weight	39 kg/ 86 lb

*Motor available 110 volts/60 Hz or 220 Volts/50 Hz optional
 ** 35° F / 2° C Fresh Meat, lab conditions

LONG LASTING LIFE

The powerful oil bathed steel gears transmission (with no belts or pulleys to maintain) guarantees a long lasting life, with minimum noise and low maintenance cost.



LARGE PAN

The M-12-FS features a large stainless steel pan.



Includes Knife, 3/16 plate and stomper



EASY TO CLEAN

Its practical grinding system and the feed pan can be completely disassembled in a few minutes without tools reducing time spent on cleaning and maintenance operations.



Grinding system components are strong cast iron parts, with dip tin plating for hygiene and corrosion resistance.

DIMENSIONS

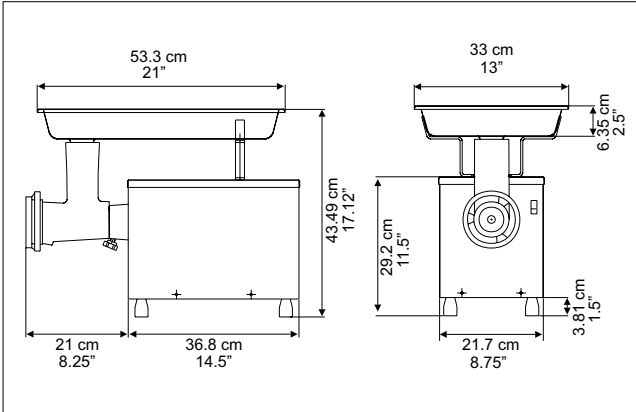

Safety & Sanitation
 Conforms UL std 763



Conforms NSF-8



Conforms CAN/CSA STD C22.2



Available only in equipment ordered under this spec

DISTRIBUTED BY

