

**LINE:** RETAIL ELECTRONIC SCALES

**MODEL:** MFQ-40L & MFQ-40LT

**PICTURE:**



**MFQ-40LT**

Available in turret model



**MFQ-40L**



REAR DISPLAY

USE
<ul style="list-style-type: none"> <li>- Convenience Stores</li> <li>- Butcher shops</li> <li>- Dairy</li> <li>- Produce</li> <li>- Bakery</li> <li>- Street markets</li> <li>- etc.</li> </ul>

CAPACITIES & DIMENSIONS		
MODEL	MFQ-40L	MFQ-40LT with turret
Capacity	40 lb	40 lb
Minimum division	.01 lb	.01 lb
Plate Dimensions	29cm x 38cm (11"x15" IN)	29cm x 38cm (11"x15" IN)

**BENEFITS**

- 40 lb capacity
- Rechargeable battery or AC adapter
- Easy to use
- Stainless steel construction
- RS-232 Serial Port to communicate with PC or printer

**LINE:** RETAIL ELECTRONIC SCALES

**MODEL:** MFQ-40L & MFQ-40LT

**BENEFITS**

**TOTAL CONTROL OF YOUR BUSINESS**  
 Cash register functions allows a better and faster service for your customers, weighing or non-weighing products can be registered at the same time, saving time. Shows the accumulated total sale.

**HYGIENIC**  
 Cabinet and plate are stainless steel constructed, hygienic and very easy to clean

**EXPEDITES CUSTOMER SERVICE**  
 The MFQ 40L scales are capable to store the price of the 100 more important products of your business, in the tower display model a visual guide can be added in order to have at the sight the memory code of each product. Also includes pre-pack function, speeding up same product packing operations.

**SPECIFICATIONS**

	MFQ-40L		MFQ-40LT	
Capacity	40 lb		40 lb	
Minimum Division	.01 lb		.01 lb	
Programmable memories	100			
Display	Liquid Crystal Display			
Back light	Included			
Power Supply	110 v / 60 Hz (220 v / 50 Hz Optional)			
Battery	Included (200 hours approximately)			
Serial port	RS-232			
Maximum Tare	20 lb		20 lb	
Plate	29 x 38 cm (11 x 15" IN)			
Maximum Price lb/max	999.99			
Maximum Price \$/max	9999.99			
Operation Temperature	-10 to 40 °C (14 to 104 °F)			
Storage Temperature	-20 to 50 °C (-4 to 104 °F)			
Net Weight	11.5 kg / 25 lb	14.2 kg / 31 lb	11.5 kg / 25 lb	14.2 kg / 31 lb
Shipping Weight	13.5 kg / 30 lb	17.6 kg / 39 lb	13.5 kg / 30 lb	17.6 kg / 39 lb

**EASY TO OPERATE**  
 The color coded keyboard allows basic and advanced operations for ease of use.



**GIVES MORE CONFIDENCE TO YOUR CUSTOMERS**  
 Double display show customers exact weight the user sees.

**EASY-TO-READ DISPLAY**  
 Because of its large alphanumeric liquid crystal display, with backlight to enhance visibility even in dark areas. The tower display model also has this feature.



**PC communication Includes PC or printer interface through serial port RS-232**

**OPTIONAL ACCESSORIES**



Deep plate

**FOLDING TURRET**  
 MFQ-40LT features a folding turret to easily transport the scale from one place to another.



**DIMENSIONS**

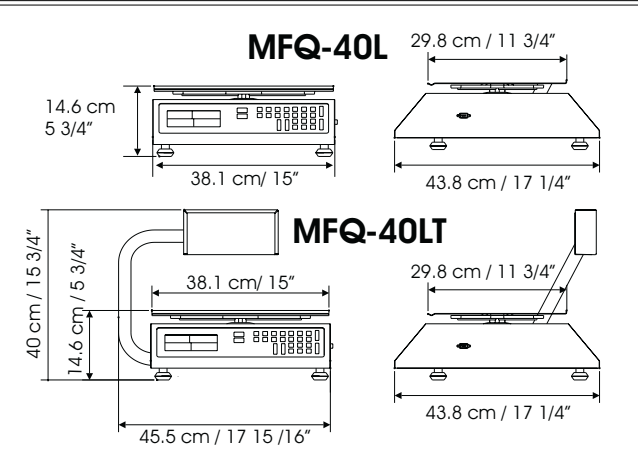

**NOM** **CE**   
\*Available only at scales ordered under this spec

DISTRIBUTED BY

